

BLOKSMA



LIFTERS
ELECTRICAL
VE 300

ELECTRICAL

- environmentally friendly, more efficient production
- quiet working
- ergonomic working routines, protecting employees
- flexible availability



MORE THAN 60 YEARS OF EXPERIENCE

- integrated concept from planning to assembly
- demand-oriented solutions for working processes
- tried and tested BLOKSMA quality and safety
- patented lifting devices since 1978
- 100% value creation in Germany



ALL ADVANTAGES AT

QUALITY AND PERFORMANCE

- fully galvanised running rails
- spindle solution for added safety
- up to 300 kg load at 220 V
- removal on all sides possible due to 720 mm upper fork edge
- high level of stability and steadiness
- proven „made in Germany“ quality
- control elements with 3 m of cable
- operating element for optional installation at your work place
- upon request, also with sensory level detection



KIND OF LOADINGS

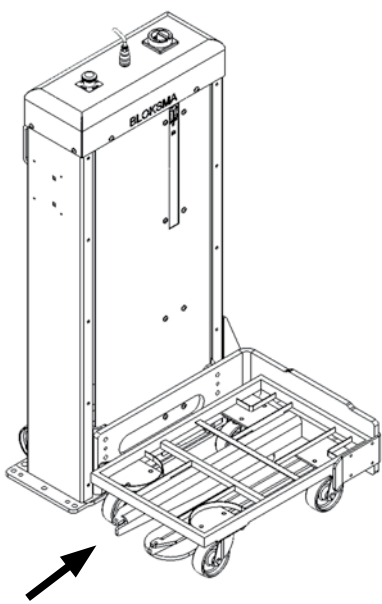

left side loading

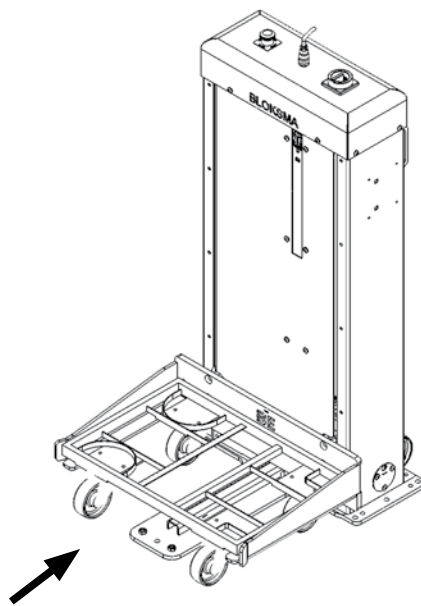

front loading

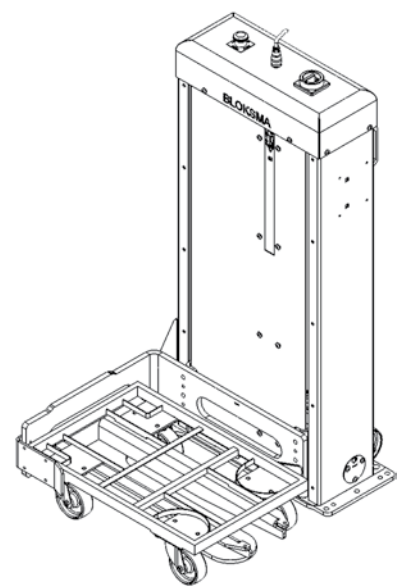

right side loading

SPECIAL SOLUTIONS ON REQUEST





MATERIAL FLOW



We are your contact for innovative material flow solutions. We continually develop new technologies to make your manufacturing process more efficient. For this we rely on our know-

how accumulated in decades, the quality of our products and the innovative strength of our engineers. Giving the assurance that everything works to perfection.



Cost-saving:
Reduction of
material stocks



**More efficient
production:**
Optimising
lead times



**Working more
ergonomically:**
Protecting employees



Reg.-Nr.: Q1 0299012



BLOKSMA

BLOKSMA ENGINEERING GmbH
Daimlerstraße 7-9
73660 Urbach
Germany

Phone +49 (0) 7181 98556-0
Fax +49 (0) 7181 98556-42

E-Mail: mail@bloksma.de
www.bloksma.de